

September 5, 2011

JCM Industries, Inc.

Stress Relief Made Simple & Economical



JCM Surge Suppressors Specification & Application Guide

JCM Industries, Inc,
P. O. Box 1220
Nash, TX 75569-1220

Call Toll Free 800-527-8482, Outside U.S. 903-832-2581

Fax Toll Free 800-874-9524, Outside U.S. 903-838-6260

www.jcmindustries.com

JCM Industries 800 Series Surge Suppressors

Water Main Breaks and Associated Problems

Pipe breaks within a distribution system occur for a variety of reasons: age, damage, corrosion, poor installation workmanship, incorrect product application and others. Frequent, inexplicable pipe breaks within a water distribution system is an indicator that forces within the pipe system are excessive and a threat to the infrastructure. Any one break is a random occurrence, but repetitive, reoccurring breaks suggests conditions within the pipe system are a danger and that actions should be taken to reduce or eliminate the risks.



One of the most common conditions within a distribution system is Water Hammer. Also known as fluid hammer, water hammer is a pressure surge or wave that results when a fluid (water) is forced to stop or change direction suddenly (momentum change). Water hammer commonly occurs when a valve is closed suddenly at an end of a pipeline system and a pressure wave propagates in the pipe.

Water Hammer conditions occur most often during:

- Sudden Valve Closure (fire hydrants, power failure, etc.)
- Pump Failure
- Check Valve slam (due to sudden deceleration, a check valve may slam shut rapidly, depending upon the dynamic characteristic of the check valve and the mass of water between a check valve and tank).
- Rapid expulsion of air from a vent or partially open valve
- Unexpected pipe breaks or damage - construction damage, traffic accidents, ground shift
- Severe changed in elevation or grade

Distribution systems are exposed to water hammer and surge conditions and these two forces can result in excessive vibration within the system, fitting failure, displacement and pipe wall ruptures (i.e. breaks).

Each break brings with it individual and multiple complications:

- Funds for manpower/materials for repair of existing system drains budget
- Loss of treated water
- Interruption of emergency, fire protection and medical services
- Residents do not like shutdowns, boil orders or street/driveway repairs
- Service reputation of municipality is compromised
- Erosion of subsurface soil base
- Exposure of contaminants to the potable system



Greater and deeper costs to water main breaks that utility managers must factor into the whole repair process from beginning to end:

- Leak detection and location
- Location of other utilities (time, manpower, expense)
- Historical locations and restoration (replacement of brick paved streets, landscaping, etc.)
- Main breaks during Holidays (manpower, overtime pay, out of service, etc.)
- Politically inconvenient locations (i.e. mayor's home, council person business, high traffic/business area, elderly residents, critical care facilities, etc.)
- Workman injuries during main break repair (risk analysis of workman's comp claims)
- Allowing for "hand dig" areas
- Rental of equipment necessary, or hire contractor to do the repair work
- Replacement of Cover (grass, asphalt, concrete)

The list of issues is endless along with the draining of the budget which postpones or eliminates planned improvements. A proactive program for the reduction and prevention of main breaks is the best solution for water distribution systems and their reputation.

JCM Industries 800 Series Surge Suppressors

Devices for Reducing and Preventing Pipe Damage Due to Water Hammer

Distribution design engineers and maintenance professionals incorporate a variety of devices to reduce and prevent the occurrence of water hammer and its damaging effects.

Hammer mitigation devices currently implemented in systems include:

- Soft Start Pumps
- Variable frequency Drives
- Elevated Tanks
- Air Release Valves
- Surge Anticipator Valves

Surge Suppression Tanks

Once the condition of water hammer has been identified, those responsible for the maintenance and security of the system can determine which devices will be most suitable for their pipelines.

Simple and Economical Solution: Installation of JCM Surge Suppressors:

The JCM 800 Series Surge Suppressor is a simple, economical solution to reduce pipeline damage and associated affects of water hammer, pressure spikes and line content velocity changes.

The “shock-absorbing” performance of JCM Surge Suppressors dampens the impact of water hammer and reduces and prevents fatal pressure stresses on the pipe joints, valves, hydrants, fitting and other critical system components. This is especially important on aging, brittle systems long overdue for rehabilitation or replacement.

Benefits of Installing JCM Surge Suppressors:

- Relieves and eases stress on the system
- Absorbs impact of water hammer vibration
- Reduces number and costs of repairs
- Reduces repair crew man hours
- Extends the life expectancy of the system, streets and pavement
- Eliminates treated water loss
- Reduce Water Quality and Service Complaints
- Protects valuable system assets
- WTP Discharge Line Main Breaks

Preventing damage to the pipelines eliminates problems of exposure of contaminants to the potable systems, erosion of the subsurface soil base, interruption of emergency, fire protection and medical services. A simple method for reducing breaks due to pressure transients is to install JCM Surge Suppressors within the system.



Patent No. 5218987



JCM Industries 800 Series Surge Suppressors

JCM Surge Suppressor Testimonials

The following testimonials from JCM Surge Suppressor users are provided with their permission. Additional users list follows.

La Grange Highlands - Cook County, Illinois

"Now if you're talking about a big system, the only thing I could recommend is to try and isolate a problem area, make your big system a small system as a test area ... and give that a try."

"I think word of mouth is more important than any kind of report you can come up with ... I would be listening more to someone who has experience with it...so I think that's a hands-on operator getting advice from another hands-on operator."

"I could immediately see a decline of main breaks after my first installations. I continued to install two or three each year when changing mains, installing hydrants, or at breaks in the more vulnerable areas."

"...Before we put the suppressor in...when the pump would turn on or turn off...you could see the gauge bounce...and now you don't see that gauge move at all. So I know there's nothing going on in the system...compared to what used to be."

"Future plans include installation of two additional suppressors this year. I'm impressed with the success of these installations."

Jeff Shepler
Water Superintendent
(708) 246-5657

Village of Hodgkins - Cook County, Illinois

"We were averaging anywhere from 20 to 30 breaks a year and was costing us a lot of money...we started installing them in our system...at this point in time we probably average one a year on the old system and we haven't had any on the new system..."

"They worked almost instantly after we put the first ones in."

"We have been able to upgrade more of our system...put in new mains where we needed to and upgrade our fire hydrants"

"We just last year spent one hundred ten thousand dollars on electronic radio read meters and a computer system so we don't have to go out and read meters. We'd saved enough money to pay for this right out of the budget with no financing."

"I know it saved us hundreds of thousands of dollars in the past ten years. We finally have money in our budget to do other things with and not pay (for) all these repairs."

Jim Barnes
Water Superintendent since 1992
(708) 579-6700

Village of Burr Ridge - DuPage County, Illinois

"Main breaks are terrible...and used to happen in the middle of the night or on the coldest of days ... they were very inconvenient."

"Residents get really angry when they can't get water out of the sink."

"One of the things with a main break...you're losing water! It gets expensive!"

JCM Industries 800 Series Surge Suppressors

"It worked for us...and I'm glad we did it. We saved a lot of money...a lot of time...and we got a lot of customer satisfaction."

Bud Coglianesse
Former Village President
(630) 654-8484

Village of Indian Head Park - Cook County, Illinois

"In one particular case, there's a water main within our town that had approximately two dozen breaks ...during one of those brakes we decided to install a surge suppressor and since that time we have not had any more water main breaks on the 2,500 foot line."

"Right now the surge suppressor is the least expensive item when the Village comes out to repair water mains."

"Your average time to install the necessary fittings and surge suppressor would be...maybe...a half-hour to forty-five minutes...so that the additional cost would be minimal considering the value of reducing the amount of main breaks, if not eliminating them."

"...It's very easy to install and the benefits are enormous"

"...from a public relations point of view we would think it's appropriate to be proactive and not reactive..."

Edward Santen
Public Works Director and
Water Superintendent since 1980
(630) 654-8484

Village of Clarendon Hills - DuPage County, Illinois

Mr. Wagner first learned about surge suppression when a consulting engineer, Novotny & Associates, had specified installation of two suppressors during a water main replacement project.

Another advisor, Dr. Henry of Fauske & Associates, a leading proponent of water hammer mitigation, recommended Heil2O Surge Suppressors.

Mr. Wagner was especially impressed by the performance in a particular instance when the Village's control system malfunctioned and the rapidly modulated pumps tripped off. With the suppressors installed, no breaks occurred. On several subsequent occasions with similar rapid flow changes, no breaks occurred.

Brian Wagner
Water Department Supervisor
(630) 323-6673

River Terminal Development - Kearny, New Jersey

River Terminal is a 300 acre, 5.5 million square foot, industrial site. This system includes miles of water main, fire main and cooling pipelines. Prior to installation of the JCM Surge Suppressor River Terminal experienced 10- 12 main breaks per year.

Since installing six units personnel have reported a dramatic decrease to three main breaks within the same time period. As this information is being given, plans include installation of two additional units in the coming months.

Emilio Guarino
(973) 589-0063
email: eguarino@riverterminal.com.

JCM Industries 800 Series Surge Suppressors

JCM Surge Suppressor Reference Contacts and Users List

Effective 01/05/2011

Community	Contact	Phone Number
Arlington Heights, IL	Terry Botterman	847-368-5800
Green Bay, WI	Paul Pavlik	920-448-3480
Burr Ridge, IL	Howard Heil (Inventor of Unit)	630-544-1200
Bellwood, IL	Reggie Alexander	708-547-3541
Hickory Hills, IL	Regan (sounds like "Reegan") Rice	708-598-7855
Haralson Cty Water, GA	Charlie Walker	770-646-6633
River Terminal Development	Emilio Guarino email: eguarino@riverterminal.com	973-589-0063

Other Users

Marshfield Utilities	WI-Marshfield
Village of Hickory Hills	IL-Hickory Hills
Village of Bridgeview	IL-Bridgeview
Lenawee County	MI-Lenawee County
Village of Oak Park	IL-Oak Park
Highland Hills Sanitary District	IL-Highland Hills
City of Jackson	MI-Jackson
Village of Fox Point	WI-Fox Point
WE Energies Water Services	WI-WE Energies
Village of Bridgeview	IL-Bridgeview
Green Bay Water Utility	IL-Green Bay Water Utility
City of Palos Hills	IL-Palos Hills
City of Schofield	WI-Schofield
Village of Bellwood, IL	IL-Bellwood
El Paso Water Utilities	TX-El Paso Water Utilities
City of Ann Arbor	MI-Ann Arbor
City of Westland	MI-Westland
Village of Glen Ellyn	IL-Glen Ellyn
City of Glenwood	IL-Glenwood
City of Country Club Hills	IL-Country Club Hills
City Water, Light and Power	IL-Springfield
City of Union Grove	WI-Union Grove
Archer Construction	IL-51st Street Sprinkler and Water Association
Village of Wheeling	IL-Wheeling
City Water, Light and Power	IL-Springfield
Village of Arlington Heights, IL	IL-Arlington Heights
City of East Peoria	IL-East Peoria
Village of Mahomet	IL-Mahomet

JCM Industries 800 Series Surge Suppressors

Typical Installations of JCM 800 Series Surge Suppressors



JCM Industries 800 Series Surge Suppressors

JCM 841 - 842 Surge Suppressor Generic Drawing - Flange Connection

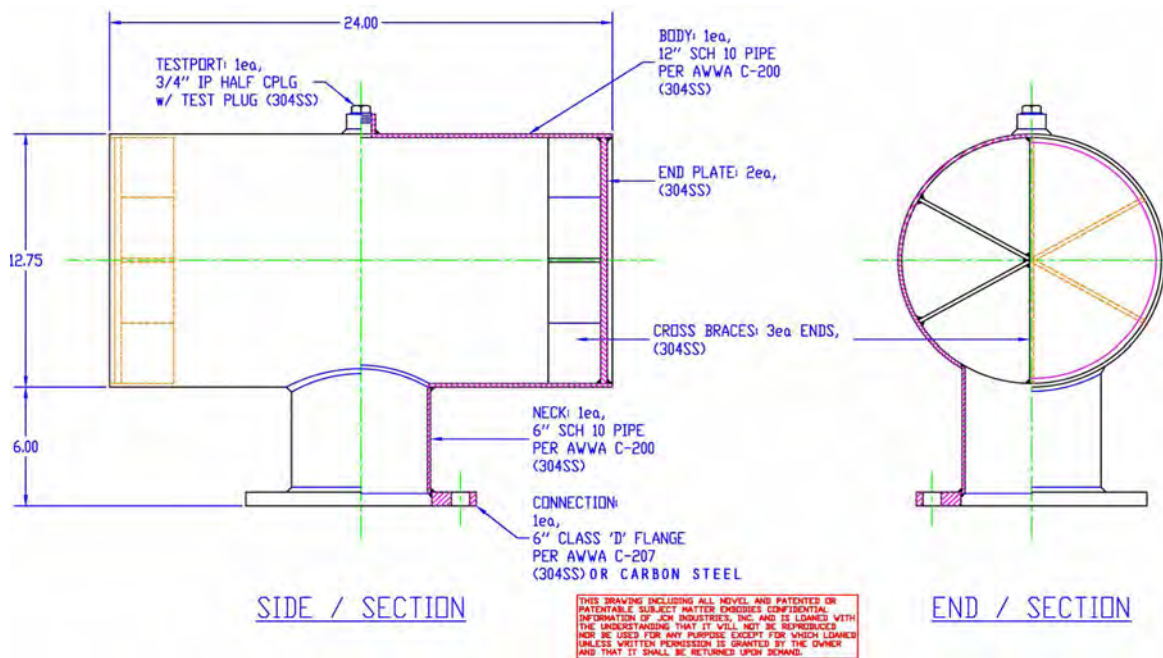

JCM 843 - 844 Surge Suppressor Generic Drawing - MJ Connection

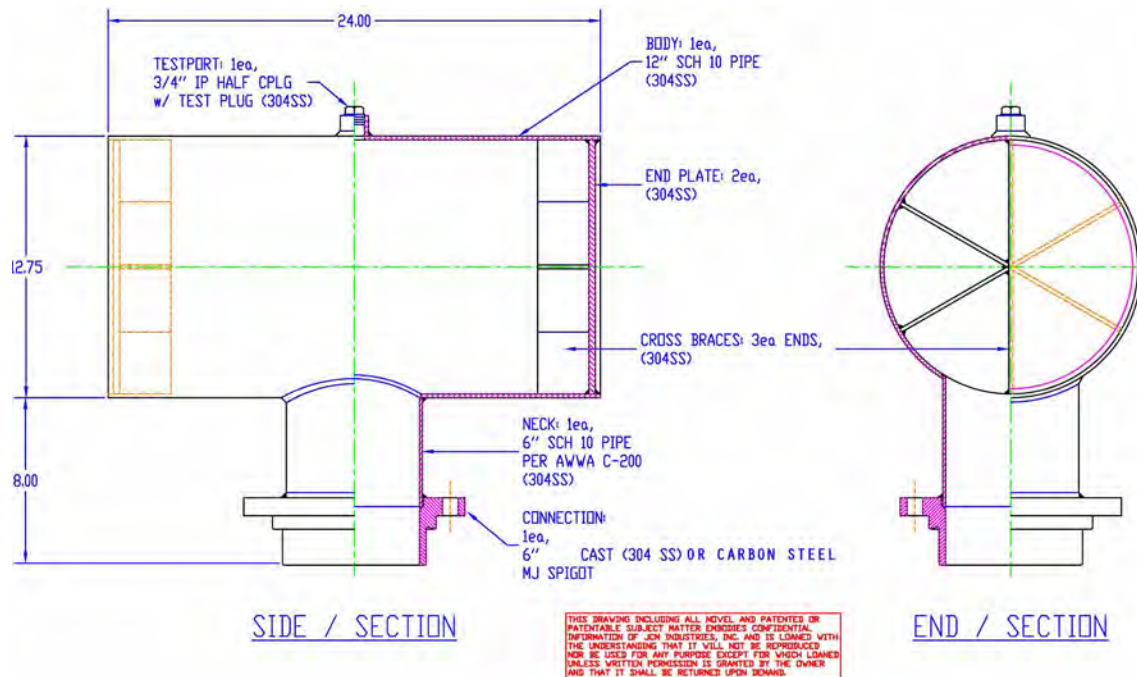

JCM Industries 800 Series Surge Suppressors

JCM 800 Series Surge Suppress Materials Specifications

Model Number	841 SS Flange	842 CS Flange	843 SS MJ	844 CSMJ
Body Material	Stainless Steel	Stainless Steel	Stainless Steel	Stainless Steel
Connection Material	Stainless Steel	Carbon Steel	Stainless Steel	Carbon Steel
Connection Type	Flange	Flange	Mechanical Joint	Mechanical Joint
Connection Standard	ANSI/AWWA C207	ANSI/AWWA C207	ANSI/AWWA C111	ANSI/AWWA C111
Fitting Overall Height	18"	18"	22"	22"
Fitting Overall Width	24"	24"	24"	24"
Outside Diameter	12.75	12.75	12.75	12.75
Approximate Weight	85 lbs	85 lbs	85 lbs	85 lbs
Test Pressure	600 psi	600 psi	600 psi	600 psi
Connection Pattern	Eight (8) 6" bolts	Eight (8) 6" bolts	Six (6) 6" bolts	Six (6) 6" bolts
Accessories Required	Tapping Sleeve, Tee, Cut-in Tee	Tapping Sleeve, Tee, Cut-in Tee	Tapping Sleeve, Tee, Cut-in Tee	Tapping Sleeve, Tee, Cut-in Tee
Body Material ASTM	ASTM A312	ASTM A312	ASTM A312	ASTM A312
Body Material	304 Stainless Steel	304 Stainless Steel	304 Stainless Steel	304 Stainless Steel
End Cap Plate	5/16" Stainless Plate	5/16" Stainless Plate	5/16" Stainless Plate	5/16" Stainless Plate
End Cap Reinforcement	3 gusset pattern	3 gusset pattern	3 gusset pattern	3 gusset pattern
Passivation	Citric Acid Aestivation	Citric Acid Aestivation	Citric Acid Aestivation	Citric Acid Aestivation
Test Port	3000# with Plug Production Feature Only	3000# with Plug Production Feature Only	3000# with Plug Production Feature Only	3000# with Plug Production Feature Only
Connection Material ASTM	ASTM 312	ASTM 312	ASTM 312	ASTM 312
Connection Material	304 Stainless Steel	304 Stainless Steel	304 Stainless Steel	304 Stainless Steel
Connection Inside Diameter	6"	6"	6"	6"

Patent No. 5218987

JCM Industries 800 Series Surge Suppressors

JCM Surge Suppressor - Frequently Asked Questions

Q. How does it work?

A. Foremost, the Surge Suppressor absorbs and dampens the effects of water hammer. In normal conditions, within the device, a short standing column of water leads upward from a primary line to a holding tank filled to a greater or lesser degree with air. In the event of a pressure spike in the primary line, the height of the water column increases, compressing the air within the tank and provides a "shock-absorber" action. The compressed air in the top of the tank expands and pushes the water back into the main line.

Q. Will water standing in the tank become stagnant?

A. JCM Surge Suppressor minimizes the issue of stagnant water in normal operational conditions with three factors:

First: Flow theory and mass conservation, the water within the tank continuously siphons out of the tank from the passing flow of water within the primary line with replenishment coming from the same source. The flow of water past the opening to the tank causes water within the tank to be siphoned out toward the flow. A faster rate of flow creates a greater siphoning action, increasing the rate of turnover in the water column.

Secondly: Pressure Fluctuations causes the tank to partially fill with water, increasing the pressure of the air trapped within the vessel. Then, as the pressure spike reduces, the water level within the tank reduces. This creates a turbulent and mixing action within the tank, replenishing the tank's contents afresh.

Thirdly: Air in the main line introduced by various situations including cavitation, collects in the raised chamber of the surge suppressor thereby reducing the overall water volume present in the device under normal operating conditions.

Under unusual conditions (such as very low or no flow within the primary line), water within the tank may not be replenished as frequently. In these cases, the water flowing through the primary line will also become inactive. If this is a concern, routine flushing of the primary line will act to flush out the Surge Suppressor as well.

Should extended periods of very low or no flow be anticipated, it may be beneficial to connect an air pressure-line to the Surge Suppressor tank. Additional air added to the pressure chamber will force a portion of the water column back into the main line thereby minimizing the standard water column volume contained within the device.

Q. Where should the suppressor be installed within the system?

A. There are a variety of methods available to determine target areas for the suppressors. Zones with undetermined causes of catastrophic failure and high occurrences of fatigue maintenance are two possible candidates. Known areas of frequent changes in pressure demands and direction of fluid flow. Distribution system records would identify the frequency and number of breaks in a specific area. Reviewing the logs of systems with computer monitoring of pressure transients that record the location, frequency and severity of pressure spikes. Some districts choose to install the suppressor at the base of fire hydrants, an area that can be the source of water hammer occurrence.

Q. How is the suppressor installed on the pipeline?

A. The unit is available with either a flanged connection stem or a mechanical joint connection stem. It is easily mounted onto a mechanical joint tee, a flanged tee or a bolt-on tapping sleeve. The fitting can be buried underground, installed in a vault or a piping gallery.

Q. What type of success have water systems experienced after installation of the suppressor?

A. JCM provides a list of water industry professional testimonials and contact references for the results of installing this product. Users have realized the benefits of installation and cost savings in the thousands. The simple, economical installation of a surge suppressor has resulted in major reduction of system failures.

JCM Industries 800 Series Surge Suppressors

JCM 800 Series Surge Suppressor INSTALLATION INSTRUCTIONS

Failure to follow installation instructions will result in
voided product warranty.

To complete this installation, the following accessories are required and are not included:

- **Mounting Fitting** - i.e. flanged tapping sleeve (for flanged connections) or cut-in mechanical joint tee with appropriate connection outlet.
- **For flange connections** - full face flange gasket and appropriate flange assembly hardware.
- **For mechanical joint connections** - standard MJ gasket and appropriate MJ assembly hardware.

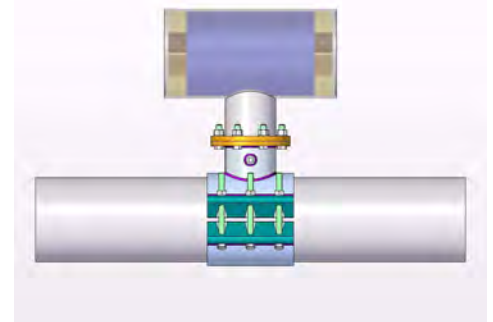

1. Install mounting fitting in/on run of pipeline. Position connection opening of mounting fitting on top (vertical) of pipe. Remove any rocks, sand and other job site debris that would prevent the gasket from seating in/on the connection opening.
2. For flanged connections, install full face flange gasket. For mechanical joint connection, install mechanical joint gasket (gaskets are not included). Inspect gaskets for any nicks, gouges or tears. Slight lubrication of the gasket with soapy-water mixture will ease installation of fitting.
3. Install Surge Suppressor on mounting fitting matching the connection stem on suppressor to the mounting fitting (mechanical joint or flanged). Surge Suppressor should be installed on the vertical of the pipe. (See reverse diagram 3 & 4) Appropriate blocking under the mounting fitting and surge suppressor is required. Improper support can result in undo stress.
4. Double check the length of flange/MJ connection bolts and confirm proper length for installation. Install flange bolts/mechanical joint connection bolts. Hand tighten bolts and confirm even compression of the gasket.
5. Tighten connection bolts to minimum 90 ft. lbs. torque making sure the gap between the two flanges is equally spaced around the outlet. Continue to tighten bolts in a "star" pattern, repeating the process until proper torque is reached. Place the 1/2" load bearing set pins in tapped holes and tighten set pins to minimum of 50 ft. lbs of torque. JCM recommends the use of a torque wrench to ensure proper torque levels are reached.
6. Confirm that the threaded outlet plug is tightened to 50 - 70 ft. lbs. of torque. Tighten if necessary, Threaded outlet is utilized for fabrication process; plug may loosen during shipment.
7. Confirm watertight application of all components. When testing the assembly the application should be treated with caution to prevent damage due to thin wall, flexible or brittle pipe conditions. Inspection and verification of the pipe integrity is the responsibility of the end user. For inquiries, contact JCM Industries, Inc.

Note: See reverse for diagrams.

IMPORTANT INSTALLATION NOTE:

To prevent damage to the unit during future excavation operations, permanently mark the curb & street location of the unit, or record the location in the distribution system mapping program.

JCM Industries 800 Series Surge Suppressors

JCM 800 Series Surge Suppressor INSTALLATION INSTRUCTIONS

Failure to follow installation instructions will result in voided product warranty.

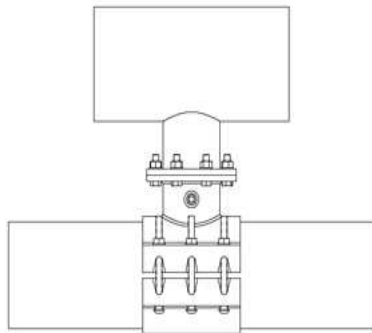
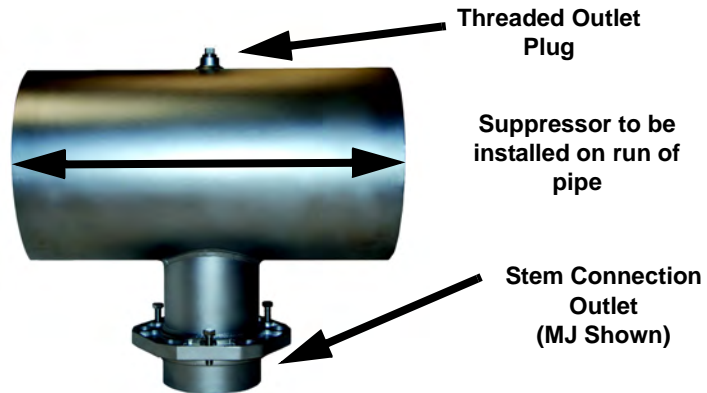

Diagram 3
Flanged Stem Connection

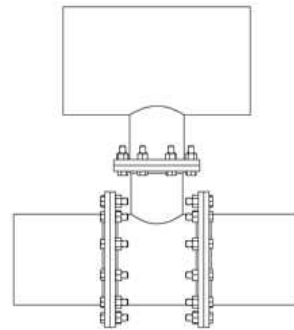
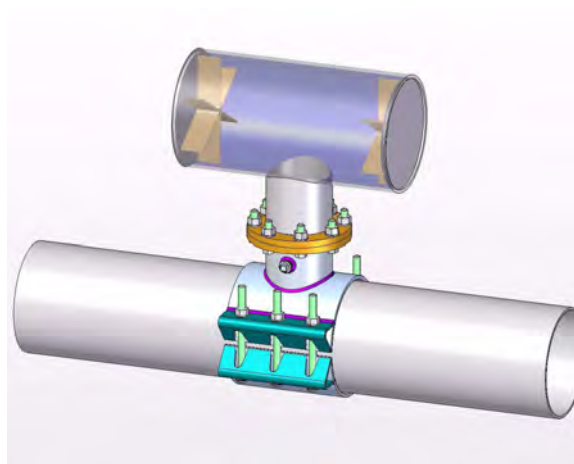

Diagram 4
MJ Stem Connection



Typical Installation
Flanged Stem Connection

JCM Industries Pipe Repair Fittings

JCM Industries features a full line of pipe repair products including Universal Clamp Couplings, Patch Clamps, Bell Joint Repair Clamps and Low Pressure, Gravity Flow Repair Clamps. These fittings are available in a variety of designs and material combinations to meet the application and environmental needs. JCM Repair Fittings are fabricated of certifiable stainless steel materials and quality castings to provide corrosion resistance and eliminate mechanical weaknesses. Balanced design and heavy duty hardware provide an efficient transfer bolt torque energy to gasket compression to provide a water tight repair. JCM Repair Fittings are available with material options to best serve many industries including: potable water, industrial, sanitary sewer systems, gas, oil, irrigation and plumbing. For specific product information, contact JCM Industries Sales Team.

PRODUCT	NUMBER & TYPE	APPLICATION, SIZES AND INFORMATION
	101 Universal Clamp Coupling - Standard Range	Most popular and economical clamp provides a full circumferential seal and wide range. Sizes 1-1/2" - 12".
	102 Universal Clamp Coupling - Extended Range	This multi-band clamp provides a full seal and offers extended range, heavy duty design and extra safety factor in larger sizes. Sizes 4"- 60".
	121 Gas Repair Clamp	This popular and economical clamp provides a full circumferential seal permanently repairing cast iron and steel gas service lines. Sizes 2" - 12".
	103 Tapped Universal Clamp Coupling - Standard Range	Repair clamps with tapped outlets are recommended for replacement of pulled out corporation stops and in applications where pipe reinforcement is necessary. Taps 3/4" - 2".
	104 Tapped Universal Clamp Coupling - Extended Range	
	123 Gas Service Clamp	
	131 All Stainless Steel Univ. Clamp Coupling - Standard Range	All stainless version of the popular single band clamp provides a full circumferential seal and wide range. Sizes 1-1/2" - 12".
	132 All Stainless Steel Univ. Clamp Coupling - Extended Range	All stainless multi-band clamp provides a full seal and offers extended range, heavy duty design and extra safety factor in larger sizes. Sizes 4" - 60".
	151 All Stainless Gas Repair Clamp	All Stainless Steel construction provides extra corrosion resistance for permanent repair of cast iron and steel gas service lines. Sizes 2" - 12".
	133 All Stainless Tapped Univ. Clamp Cplg. - Standard Range	All stainless repair clamps with tapped outlets are recommended for replacement of pulled out corporation stops and in applications where pipe reinforcement is necessary. Taps 3/4" - 2".
	134 All Stainless Tapped Extended Range	
	153 All Stainless Gas Service Clamp	
	105 Collar Leak Clamp	This specialty clamp provides a quick, simple means of repairing solvent weld PVC pipe joints. Pressure pipe sizes 2" - 8". Plastic Irrigation Pipe sizes 4" - 15".
	135 All Stainless Collar Leak Clamp	

JCM Industries Pipe Repair Fittings

PRODUCT	NUMBER & TYPE	APPLICATION, SIZES AND INFORMATION
	<p>161 All Stainless Steel Fabricated Lug Clamp</p> <p>162 All Stainless Steel Fab Lug Clamp - Extd Range</p> <p>163 Tapped All Stainless Steel Fabricated Lug Clamp</p>	<p>All stainless steel fabricated repair clamp provides full circumferential seal and wide range. All stainless construction is suitable for hot, acidic or corrosive environments. Sizes 2" - 12".</p>
	<p>171 Universal Clamp Coupling - Removeable Lug - Standard Range</p> <p>172 Universal Clamp Coupling - Removeable Lug - Extended Range</p>	<p>Universal Clamp Coupling with unique feature of removeable lug. Lug slides off to accommodate installations in rockbound soils, narrow piping galleries and other limited space installation applications. Sizes 1-1/2" - 12"</p> <p>Multi-band clamp provide full circumferential seal and the removeable lug feature. Heavy duty design and extra safety factor in large sizes. Sizes 4" - 60"</p>
	<p>106 Bell Joint Leak Clamp for IPS PVC</p>	<p>A bell joint repair clamp specifically for rubber joint IPS size plastic pipe. Clamp also fits solvent weld joints and many standard steel pipe threaded couplings. Sizes 4" - 8".</p>
	<p>143 Bell Joint Leak Clamp for Cast Iron, Ductile Iron, C-900 PVC</p>	<p>Bell joint clamps for leaking caulk and rubber joints on cast iron and ductile iron. Sizes 4" - 36". 14" and larger fittings are fabricated. Larger than 36" sizes available on request.</p>
	<p>108 Universal Clamp Coupling for Sewer Pipe</p> <p>138 All Stainless Steel Univ. Clamp Cplg. for Sewer Pipe</p>	<p>A full circumferential clamp coupling to join and repair various types of sewer pipe, single and multi-band versions. Sizes 4" - 48".</p> <p>All stainless full circumferential clamp coupling to join and repair sewer pipe, single and multi-band versions. Sizes 4" - 48".</p>
	<p>168 Fabricated Lug Stainless Steel Clamp for Sewer Pipe</p> <p>169 Fabricated Lug Multi Band Stainless Steel Clamp for Sewer Pipe</p>	<p>All stainless steel fabricated repair clamp provides full circumferential seal and wide range. Suitable for low pressure, gravity flow and slip pipe connection applications.</p>
	<p>110 Patch Clamp</p> <p>111 Full-Repair Clamp</p>	<p>Fast, economical repair clamps to permanently repair pinholes, punctures or splits in steel pipe. Sizes 1/2" - 24".</p> <p>Fully gasketed repair clamp. Especially recommended for repairs to heavily damaged pipe and pipe with reduced diameter due to corrosion. Steel Sizes 1/2" - 2".</p>
	<p>112 Heavy Duty Patch Clamp - Single Band</p> <p>113 Heavy Duty Patch Clamp - Multi-Band</p>	<p>Heavy duty single band patch clamp for repairing pinholes, punctures or splits. Sizes 1-1/2" - 12".</p> <p>Heavy duty multi-band clamp offers increased performance and range in repairing pinholes, punctures and splits. Sizes 10" and larger.</p>

JCM Industries Engineered Pipe Repair Fittings

JCM provides fittings for repairs to all types and sizes of pipe. Selection of the proper fitting is the determining factor to the success of the repair and returning the system to its original service capacity. This chart is an introduction to the Engineered Repair Fittings JCM fabricates and the types of applications for which they would be considered. For specific product application recommendations, contact the JCM Sales Team.

PRODUCT	TYPE OF PIPE	APPLICATION, SIZES AND INFORMATION
 <p>JCM 114 MJ Repair Sleeve</p>	Cast Iron Ductile Iron Asbestos Cement Steel PVC	114 Split Repair Sleeve repairs cracks, splits, longitudinal and circumferential breaks. Especially useful for repairs to critical lines that cannot be shut down. Product is custom fabricated to accommodate all types and sizes of pipe. Pipe Sizes 6" and larger.
	Cast Iron Ductile Iron Asbestos Cement Steel PVC	114 Bell Joint Repair Sleeve repairs cracked cast iron bells, split or leaking couplings, leaking joints. Repair fitting "houses" the leaking connection and provides permanent water tight joint. Product is fabricated to specific application dimensions, ensuring custom fit over damaged area. Pipe Sizes 6" and larger.
 <p>JCM 116 Repair Sleeve for Concrete Steel Cylinder Pipe and Large Diameter Pipe</p>	C301/SP-5/PCCP C301/SP-12/ECCP C303/SP-3/RCCP	Repairs holes, punctures, construction damage, and corroded areas on PCCP. Repairs directly on the steel cylinder preventing further corrosion damage to pipeline. Requires minimal excavation of pipeline. Pipe Sizes 14" and larger.
	Cast Iron Ductile Iron Steel Other large diameter rigid pipe	Repairs holes, punctures, construction damage and corrosion areas on large diameter pipe. Concentration of gasket compression around damage area allows for high working pressure capability. Pipe Sizes 14" and larger
 <p>JCM 136 Heavy Duty Stainless Steel Repair Sleeve</p>	Cast Iron Ductile Iron Steel Asbestos Cement PVC	Repairs holes, punctures, splits, cracks, breaks and other serious damage to pipelines. The fully gasketed stainless shell provides a complete seal on the full circumference of the pipe. Heavy duty tapping sleeve lug system provides for higher bolt torque capabilities. Pipe Sizes 6" and larger.
 <p>JCM 118 Large Diameter and Non-Standard Contour Pipe Repair Sleeve</p>	Cast Iron Ductile Iron Steel Asbestos Cement PVC HDPE	Repairs holes, punctures, construction damage and corrosion areas on large diameter pipe. Accommodates application parameters such as limited space, non-standard pipe diameters, uneven pipe surfaces, out of round pipe high working pressure systems. Pipe Sizes 12" and larger.



Pipe Outside Diameter Guide

SMALL DIAMETER PIPE SIZES

NOMINAL PIPE SIZE (INCHES)	1/2	3/4	1	1-1/4	1-1/2	2	2-1/2
COPPER TUBING	.63	.88	1.13	1.38	1.63	2.13	2.63
STEEL & PLASTIC PIPE	.84	1.05	1.32	1.66	1.90	2.38	2.88

IMPORTANT: This Pipe O.D. Guide is furnished for your convenience and is based on the latest pipe standards and information supplied by pipe manufacturers. Due to occasional changes and variances in outside diameters, the pipe O.D. should always be verified before ordering fittings.

STANDARD PRESSURE PIPE SIZES

NOMINAL PIPE SIZE (INCHES)	3	4	5	6	8	10	12	14	15	16	18	20	24	30
COPPER TUBING	3.13	4.13	5.13	6.13										
STEEL & PLASTIC PIPE (SDR 26,21 & SCHEDULE)	3.50	4.50	5.56	6.63	8.63	10.75	12.75	14.00		16.00	18.00	20.00	24.00	30.00
PLASTIC IRRIGATION PIPE (PIP)		4.13		6.14	8.16	10.20	12.24		15.30		18.70	22.05	24.80	
PLASTIC SEWER PIPE (SDR 35)		4.22		6.28	8.40	10.50	12.50		15.30		18.70		24.80	
PLASTIC (PVC) AWWA C-900/C-905/C-909		4.80		6.90	9.05	11.10	13.20	15.30		17.40	19.50	21.60	25.80	
POLYETHYLENE PIPE (IPS SIZE)	3.50	4.50		6.63	8.63	10.75	12.75	14.00		16.00	18.00	20.00	24.00	30.00
POLYETHYLENE PIPE (DIP SIZE)		4.80		6.90	9.05	11.10	13.20	15.30		17.40	19.50	21.60	25.80	32.00

DUCTILE IRON PIPE	3.96	4.80		6.90	9.05	11.10	13.20	15.30		17.40	19.50	21.60	25.80	32.00	
CAST IRON	CLASS 100 - 250 AWWA	3.96	4.80		6.90	9.05	11.10	13.20	15.30		17.40	19.50	21.60	25.80	32.00
	CLASS A AWWA PIT CAST	3.80	4.80		6.90	9.05	11.10	13.20	15.30		17.40	19.50	21.60	25.80	31.74
	CLASS B AWWA PIT CAST	3.96	5.00		7.10	9.05	11.10	13.20	15.30		17.40	19.50	21.60	25.80	32.00
	CLASS C - D AWWA PIT CAST	3.96	5.00		7.10	9.30	11.40	13.50	15.65		17.80	19.92	22.06	26.32	

ABESTOS CEMENT PIPE	Class 100	MACHINED END	3.74	4.64		6.91	9.11	11.24*	13.44*	15.07		17.15	19.90	22.12	26.48	33.12	
		FLINTITE ROUGH BARREL	3.94	4.90		7.13	9.33	11.30	13.42	15.45		17.60					
		FLUID-TITE ROUGH BARREL	3.93	5.05		7.16	9.32	11.46	13.70	15.36		17.50	20.44	22.50	27.17		
		PERMAFLEX ROUGH BARREL		4.84		7.15	9.35	11.47	13.74	15.55		17.55	20.50	22.70	27.15		
		RING-TITE ROUGH BARREL	3.95	4.92		7.19	9.39	11.47	13.74	15.51		17.65	20.44	22.68	27.12	33.80	
		MIN. STD. ROUGH BARREL		4.79		7.05	9.22	11.25	13.37	15.36		17.50					
		MAX. STD. ROUGH BARREL		5.26		7.40	9.57	11.77	14.04	15.80		17.94					
	Class 150	MACHINED END	3.84	4.81		6.91	9.11	11.66	13.92	16.22		18.46	20.94	23.28	27.96	35.00	
		FLINTITE ROUGH BARREL	4.40	5.06		7.13	9.33	11.88	14.14	16.48		18.72					
		FLUID-TITE ROUGH BARREL	4.03	5.14		7.12	9.32	11.85	14.11	16.41		18.65	21.20	23.54	28.22		
		PERMAFLEX ROUGH BARREL		5.00		7.20	9.40	11.92	14.20	16.50		18.75	21.30	23.64	28.32		
		RING-TITE ROUGH BARREL	4.13	5.07		7.17	9.37	11.92	14.18	16.48		18.72	21.30	23.64	28.32	35.42	
		MIN. STD. ROUGH BARREL		4.97		7.07	9.27	11.82	14.08	16.38		18.62					
		MAX. STD. ROUGH BARREL		5.32		7.37	9.62	12.12	14.38	16.73		18.97					
	Class 200	MACHINED END	3.84	4.81		6.91	9.11	11.66	13.92	16.22		18.46	22.18	24.66	29.62	37.06	
		FLINTITE ROUGH BARREL	4.17	5.32		7.26	9.44	11.88	14.14	16.53		18.84					
		FLUID-TITE ROUGH BARREL	4.18	5.32		7.36	9.46	11.88	14.11	16.44		18.74					
		PERMAFLEX ROUGH BARREL		5.32		7.25	9.50	11.95	14.20	16.55		18.90	22.54	25.02	29.98		
		RING-TITE ROUGH BARREL	4.17	5.33		7.32	9.50	11.92	14.18	16.59		18.90	22.54	25.02	29.98	37.48	
		MIN. STD. ROUGH BARREL		5.22		7.26	9.39	11.77	14.03	16.44		18.74					
		MAX. STD. ROUGH BARREL		5.57		7.60	9.79	12.12	14.38	16.88		19.19					
	NOMINAL PIPE SIZE (INCHES)		3	4	5	6	8	10	12	14	15	16	18	20	24	30	

* Flintite ME is 10.89 for 10" and 12.99 for 12" sizes.



JCM INDUSTRIES, INC.
 P.O. Box 1220 • Nash, Texas 75569-1220
 Call Toll Free 800-527-8482, Fax Toll Free 800-874-9524
 Outside U.S. Call 903-832-2581, Outside U.S. Fax 903-838-6260
www.jcmindustries.com



©JCM Industries, Inc.
 Surge Suppressors 0811