

Model 610 Fitting Restrainer IPS PVC, C-900 PVC & HDPE

NOTE: DO NOT REMOVE WOOD SPACER - SEE INSTRUCTION STEP #2

Clean and scrape pipe. Remove any scale, pipe wrap, debris or dirt that may interfere. Inspect pipe for integrity, size, outside diameter and surface irregularities. Confirm the proper size and range of restrainer. Inspect fitting to ensure all parts are included.

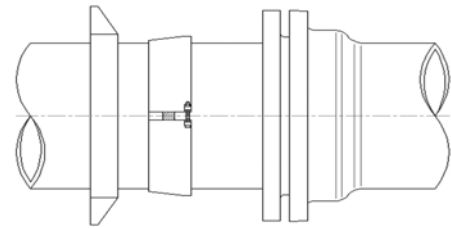
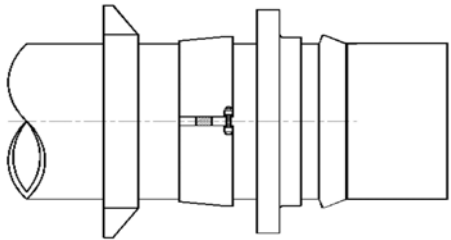

- 1) Install, in order, onto pipe spigot: casing gland, inner serrated ring, mechanical joint follower gland and gasket.

- 2) Insert pipe spigot end into the Mechanical Joint (MJ) fitting, sliding the MJ gasket and gland forward to seat into the fitting cavity.

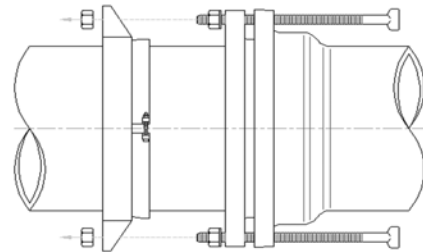
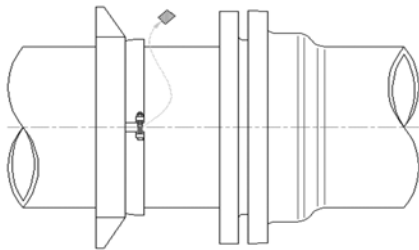

- 3) Position inner serrated ring 2-1/2" from MJ gland, adjust serrated ring restrainer square with pipe and remove wooden spacer, tighten positioning pin firmly (using allen wrench provided) until ring is secure on pipe. Slide casing gland forward to seat onto the inner ring.

- 4) Insert the extra long T-Bolts through the MJ fitting and gland. After placing a nut behind the follower gland, align the bolts through the casing gland. Tighten the back (second) nut to 65 ft./lbs.

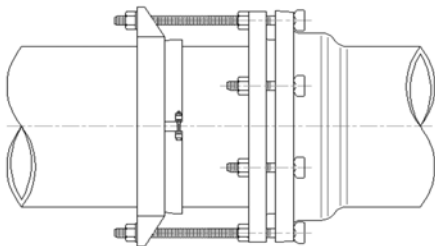

- 5) Install the remaining MJ bolts and evenly tighten all follower gland nuts to AWWA standards for mechanical joints.

NOTE: IF PIPE IS OUT OF ROUND, ROTATE FITTING UNTIL THE BEST FIT IS ACHIEVED. Pipe O.D.'s must be within industry set tolerances for proper restrainer installation.

*Ensure fitting is suitable for application (confirm size, materials, pressure ratings, line content, meets local governing & association standards, etc.). Pipeline operation forces, including pressure fluctuations, thermal expansion/contraction, movement/shifting, etc. will influence the success of the application. Inspection of the pipe integrity is the responsibility of the end user. JCM recommends the use of calibrated torque wrench. Failure to follow installation instructions will result in voided product warranty.



Installation Instructions

Model 620 Bell Joint Restrainer IPS PVC, C-900 PVC Pipe

NOTE: DO NOT REMOVE WOOD SPACER - SEE INSTRUCTION STEP #2

Clean and scrape pipe. Remove any scale, pipe wrap, debris or dirt that may interfere. Inspect pipe for integrity, size, outside diameter and surface irregularities. Confirm the proper size and range of restrainer. Inspect fitting to ensure all parts are included.

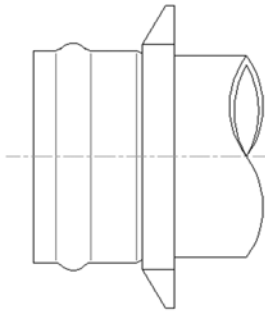

- 1) Slide one casing gland down the pipe barrel to seat against the bell slope (larger opening toward bell).

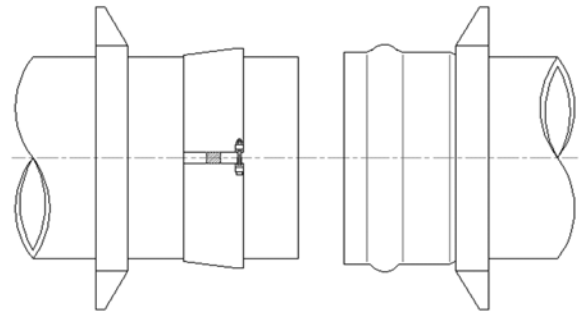

- 2) In order, slide the second casing gland and inner serrated ring onto the pipe spigot - connect the bell and spigot per standard pipe installation practices.

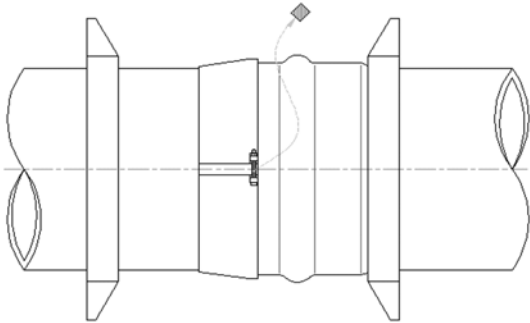

- 3) Position inner serrated ring against the bell face and remove the wooden spacer; tighten the positioning pin firmly (using allen wrench provided) until ring seats securely on pipe.

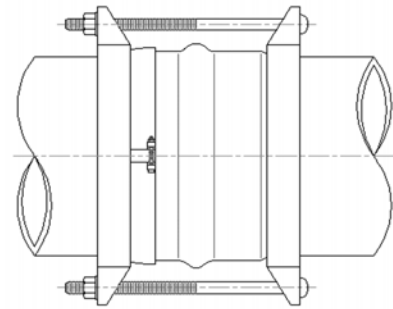

- 4) Slide the casing gland onto the inner serrated ring. Insert oval-neck bolts through corresponding gland holes and tighten to 65 ft./lbs.

NOTE: IF PIPE IS OUT OF ROUND, ROTATE FITTING UNTIL THE BEST FIT IS ACHIEVED. Pipe O.D.'s must be within industry set tolerances for proper restrainer installation.

*Ensure fitting is suitable for application (confirm size, materials, pressure ratings, line content, meets local governing & association standards, etc.). Pipeline operation forces, including pressure fluctuations, thermal expansion/contraction, movement/shifting, etc. will influence the success of the application. Inspection of the pipe integrity is the responsibility of the end user. JCM recommends the use of calibrated torque wrench. Failure to follow installation instructions will result in voided product warranty.